



TH450

PATENTED IP68



Colori a richiesta - Colours on demand



Pressacavi bimateriale ad elevata tenuta.
Doppia protezione all'acqua.
Guarnizioni aggiuntive non richieste.
Kit di fornitura: Corpo + dado montato.

*Cable gland in bimaterial with high seal. Double water protection.
Supply kit: body + nut assembled.*

Dati tecnici - Technical data(*)

5 Bar	IP68	Min-Max Ø			4÷9,5mm
PG9	M16				
		M16		M16	
Ø cavi e gamma ancoraggio cavo Sealing range and clamping range of cable anchorage		7 mm		9,5 mm	
Torsione installazione Installation torque		1,5 /Nm		1,5 /Nm	
Torsione installazione dado Cap nut installation torque		1 /Nm		1 /Nm	
Torsione installazione controdado Locknut installation torque		1 /Nm		1 /Nm	
Categoria d'impatto Impact category		4		4	
Tipo di ancoraggio cavo Type of cable anchorage		A		A	

Materie prime - Raw material

Materia plastica - Plastic Material

PA66 UL94 V2 GWT 850°C

Nero - Black

Grigio - Grey

RAL 7035

Gomme - Rubbers

Gomma termoplastica TPE-V
Thermoplastic rubber TPE-V

-20°C

+85°C

Norme - Standards

EN 50262-(VDE0619):2005-05
EN 50262:1998+A1:2001 + A2:2004



Famiglia
- Family



Codice - Part number

T H A . 4 5 0 . X 0 X

Max Ø 7mm

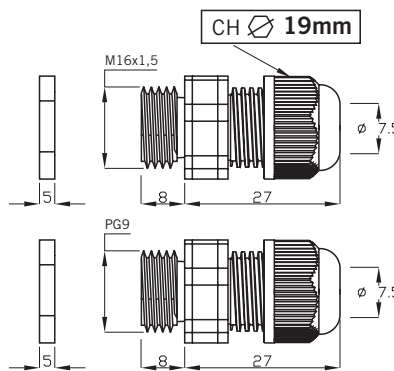

THA.450.A0A Nero - Black
THA.450.A0E Grigio - Grey
Guarnizione sovrastampata gialla

THA.450.A1A Nero - Black
THA.450.A1E Grigio - Grey
Guarnizione sovrastampata grigio
antracite

Max Ø 9.5mm

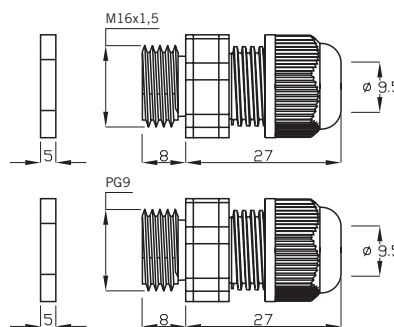

THA.450.B0A Nero - Black
THA.450.B0E Grigio - Grey
Guarnizione sovrastampata gialla

THA.450.B1A Nero - Black
THA.450.B1E Grigio - Grey
Guarnizione sovrastampata grigio
antracite

Accessori - Accessories



6000046CC Nero - Black

6000046CE Grigio - Grey 7035

CH **22mm**



6002002CC Nero - Black

6002002CE Grigio - Grey 7035

Foro - Hole **Ø 7,5**

Edizione: Novembre 2007

Eventuali modifiche e migliorie sui dati tecnici o sul prodotto potranno essere effettuate senza preavviso.
All technical data or other eventual product modifications and improvements can be carried out without notice
Techno S.r.l. - technology & innovation - tel. +39.031.976445 - www.techno.it - info@techno.it

Kit di fornitura non assemblato THA....
Unassembled kit THA....

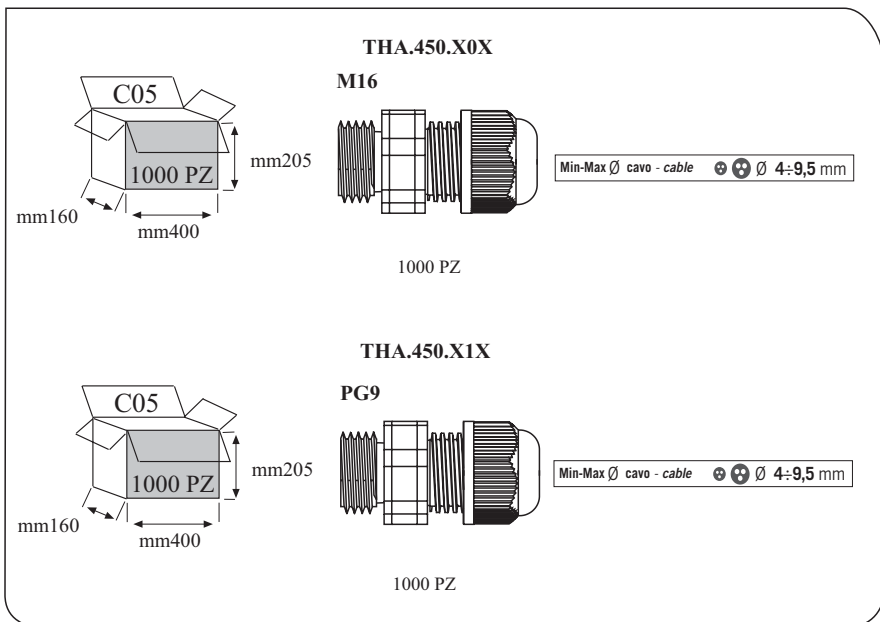

Kit di fornitura assemblato THZ....
Assembled kit THZ....

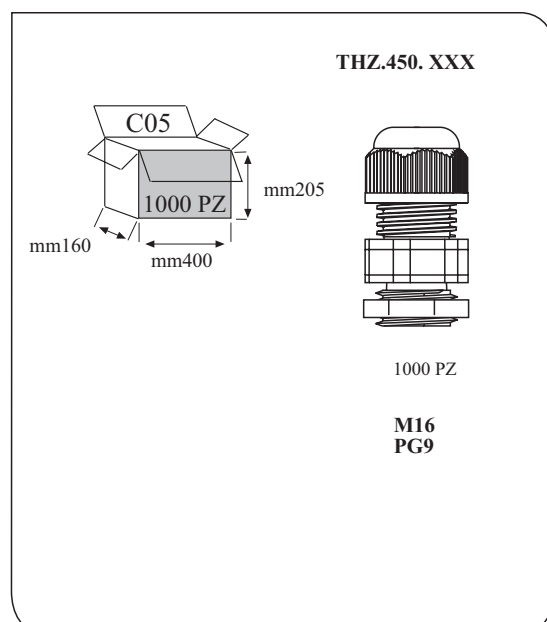

Kit di fornitura con versionamenti e confezionamenti speciali THK....
Special custom packed version THK....

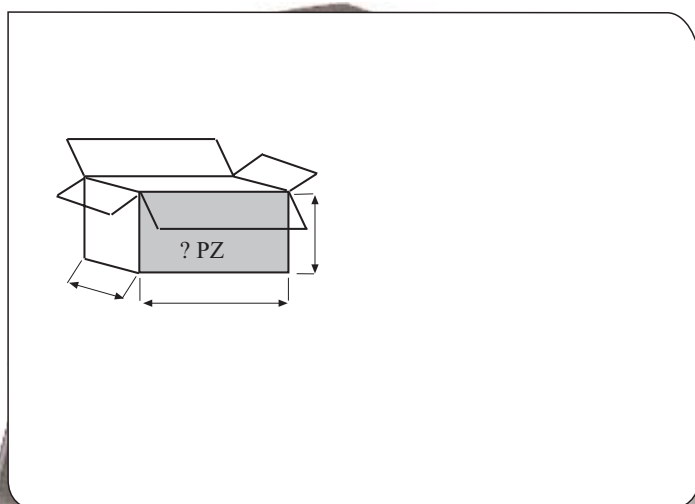

Kit di fornitura imbustati THR....
Enveloped supplying kit THR....

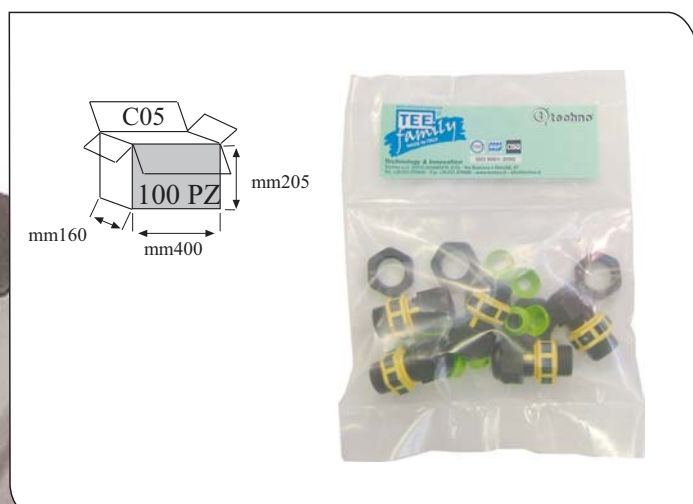

ABOUT US

Hylec-APL is a well established Component Distributor specialising in the bulk supply of Terminal Blocks, Connectors and Cable Glands to major OEM's, Sub-Contractor Manufacturers and leading Distribution organisations into both the Electromechanical and the Electronics sectors.

Hylec APL can provide a wide range of product options and application solutions including access to many thousands of line items from its extensive and largely exclusive supplier base. Hylec APL maintains a large UK stock profile at its base in Northants, which is geared to reflect popular market demand whilst offering enhanced product availability to its many customers.

In addition to its core product lines of Terminal Blocks and Connectors – both Electromechanical and Electronic variants - Cable Glands and Cable entry components, Hylec APL has recently extended its range to include LED's, Switches, Buzzers, Relays, Fuses and DIN Rail Mounting Enclosures. This evolutionary development is designed to not only widen market appeal but also to provide the customer with greater choice, the potential for supplier consolidation and the commercial benefits of economies of scale.

Subject to availability, delivery methods include next day carrier as standard and customer specific options, such as special packaging requirements, can be readily considered.

Product choice is supported by a wealth of product knowledge and application experience, and our technical sales team will be only too pleased to assist in the process of correct product selection.

The vast majority of products hold recognised Industrial Safety Approvals and these together with samples can be supplied upon request.

Value for money consistent with the supply of the highest possible quality of products and service is our number one priority.



APL

Hylec Components Ltd - Andromeda Products Ltd

T: +44 (0)1933 234400 ■ F: +44 (0)1933 234411
E: sales@hylec-apl.com ■ W: www.hylec-apl.com



MAKING THE RIGHT CONNECTIONS